

Electric Boilers

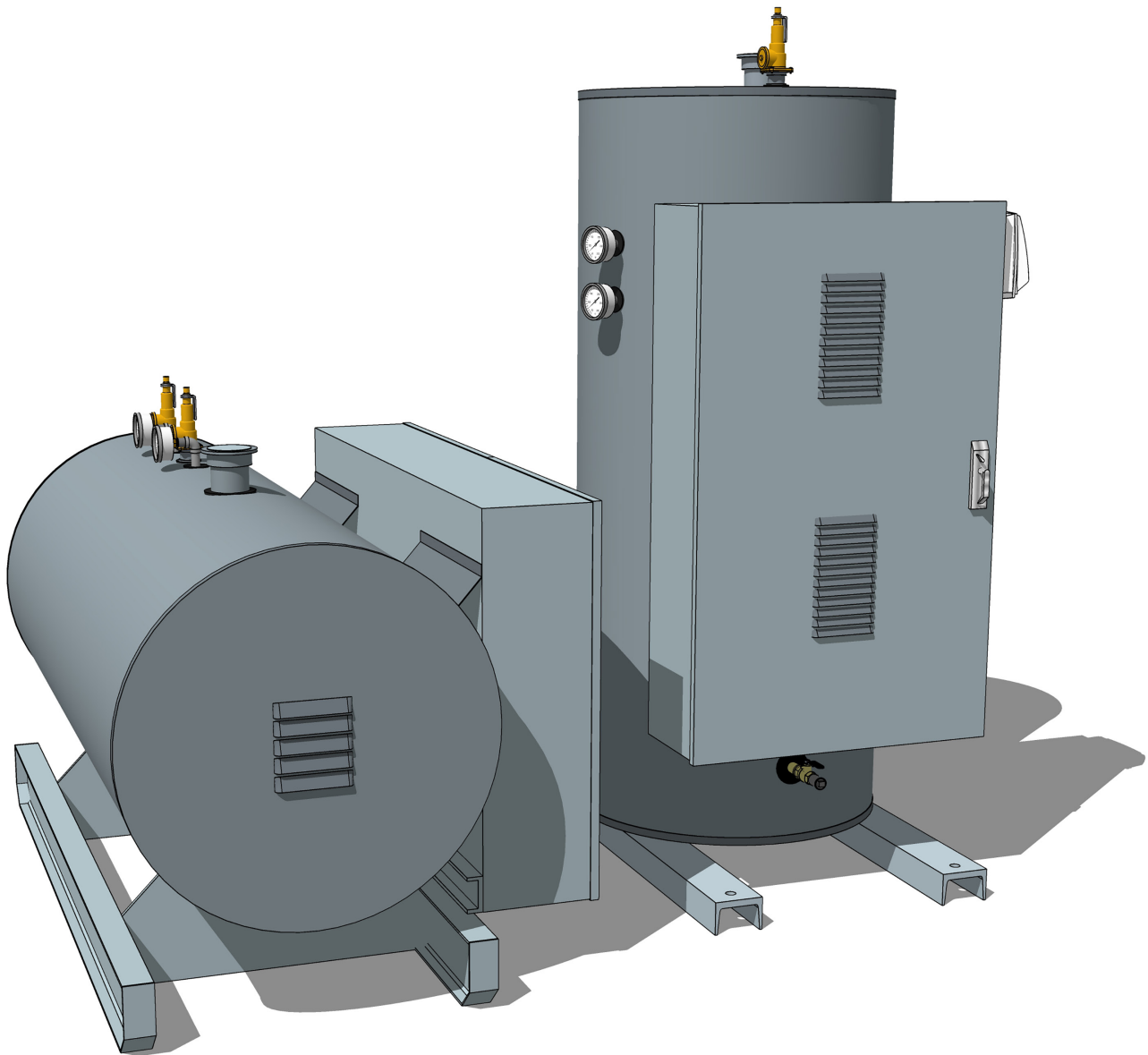

Hot Water and Steam Heating *Vertical or Horizontal*



CEMLINE CORPORATION
P.O. BOX 55 CHESWICK, PENNSYLVANIA 15024
Phone: (724) 274-5430 FAX: (724) 274-5448
www.cemline.com

Cemline® Electric Boilers

Standard Equipment

Cemline Electric Boilers are designed for hydronic heating systems and process heating. Cemline Electric Boilers are furnished as a complete factory package for one source responsibility. Installation requires only pipe lines and power leads. We offer many optional extras for applications where such features are desired.

Standard EB Package

Features

Storage tank—A.S.M.E. Code Constructed National Board Registered—H or S Stamp	A.S.M.E. Code stamping and registration offer the assurance of quality controlled construction.
3" fiberglass insulation	Prevents heat loss to cut operation costs—meets or exceeds latest ASHRAE standards.
20 Gauge steel jacket with hammertone enamel-painted exterior	Protects insulation & provides neat finished appearance.
A.S.M.E. Pressure Relief Valves	Safety feature against excess pressure.
Thermometer & Pressure Gauge	Easy to read dials to monitor operating temperature and pressure.
Incoloy sheathed immersion	Long life elements of incoloy. Provides ease in field maintenance. Each rod individually removable and replaceable.
Standard operating controls	All components necessary for safe-complete operation—all thermostats, high limit resets, contactors, transformer, fusing pilot lights, and low water cut off wired to a NEMA terminal box.
Solid State Step Controller	Adjustable proportioning type featuring easily replaceable modular construction.
UL Listing	Boilers meet testing and inspection requirements of Underwriters' Laboratories and are so labeled and listed.
Warranty	One year against defects in materials or workmanship.

Optional Extras Available:

- Circuit breaker with or without shunt trip
- Fused or non-fused disconnect
- Voltmeter
- Ampmeter
- Time clock
- Element watt density to suit customer request
- Alarm bell
- Peak load control
- Flow switch
- Outdoor sensor
- BACnet
- Remote Setpoint
- Load programmer—or—contacts for customer supplied load programmer
- Manual reset low water level cut off
- High pressure cut off
- Ground fault detection
- NEMA IV panel enclosure
- 4" thick fiberglass insulation
- Indoor/outdoor reset
- Timers
- Feed water pump
- Safety door interlock
- Remote on/off
- Remote alarm

Electric Boilers

Standard Equipment

Cemline Electric Boilers are furnished with all accessories factory sized and mounted to insure the finest quality and most efficient package.

Tank

Cemline Boilers are constructed and stamped in strict accordance with the latest A.S.M.E. code using pressure vessel quality plate welded by certified welders. Tanks used in the boilers are built in accordance with Section IV or Section I of the A.S.M.E. Code and form H or S certificates are provided. All tanks are registered with the National Board of Boiler Pressure Vessel Inspectors and so certified. Vessels are normally built for 150 psi maximum water working pressure, or 15 psi steam. Boilers can be furnished for up to 150 psi steam working pressure.

Jacket

Cemline Boilers are neatly and attractively covered with a 20 gauge steel jacket over the fiberglass insulation. The jacket protects the insulation, and is professionally painted with superior quality enamel to allow the added advantage of an easy to maintain surface.

Insulation

Cemline Boilers are furnished with 3" thick fiberglass insulation. This high quality insulation has proven to be an extremely reliable means of minimizing heat loss and complies with current ASHRAE Standards.

Base—Support

Vertical heaters are supplied with leg supports with leveling bolts and couplings to receive pipe legs. This provides the option of mounting the unit directly on a floor or raising it with pipe legs to any desired height. Cemline Horizontal Boilers are mounted on structural I-Beam support skids which are engineered to provide correct support for the heater as a permanent base.

Electric Heating Elements

Cemline Boiler heating elements consist of one or more incoloy sheathed removable immersion rods. These rods are grouped together as three phase deltas to achieve required total kilowatt. Each rod contains resistance wire surrounded by an ample thickness of compressed magnesium oxide. Individual rods are removable and replaceable with ordinary hand tools for in the field replacement to insure worry free maintenance of the heater.

Control Circuit System

Cemline Electric Boiler control circuits are equipped with a line voltage to 120 volt isolation transformer to provide 120 volt control. This transformer is fused on the primary side and fused and grounded on the secondary side in accordance with A.S.M.E. Code, National Electric Code, and Underwriters' Laboratories.

High Limit Thermostats or Pressure Switch

Cemline Electric Boilers are provided with built in safety protection against high temperature conditions. Electric boilers are furnished with both an adjustable automatic reset type high limit and a manual reset high limit thermostat with a manual reset button. These thermostats open the control circuit if the temperature of the boiler exceeds the set point. On steam boilers, pressure switches perform the same function if the steam pressure exceeds the desired pressure.

Contactors

Cemline Electric Boilers are equipped with heavy duty magnetic contactors to close and open circuits as required for load control. The contactors are controlled by a solid state step controller.

Final Assembly & Testing

Cemline Electric Boilers are thoroughly tested prior to shipment. All components and workmanship are guaranteed for a period of one year from date of start-up or eighteen months from the date of shipment.

Fuses

Cemline Electric Boilers utilize "Class J" type fuses. Each contactor line is protected by an individual fuse which is designed to interrupt power in the event of an overload condition in that circuit.

Electric Boilers

Standard Equipment (Continued)

Cemline Electric Boilers are furnished as a complete factory package and are UL listed.

Wiring

Cemline Electric Boilers are factory wired, utilizing heat resistant, color coded copper wire. All components are factory wired to a generously sized terminal strip for solderless connections. Heaters furnished with circuit breaker or disconnect switch are factory wired to load side of breaker switch.

Low Water Cut-Off

Cemline Electric Boilers are furnished with float type low water cut-off, wired to open the control circuit on a low water condition.

Electric Control Cabinet

Cemline electric elements and controls are mounted in a NEMA 1 enclosure with key lock door.

Pilot Lights

Pilot lights are supplied to enable the operator to see the status at a glance.

Relief Valves

Cemline Electric Boilers are provided with a A.S.M.E. pressure relief valve. The valve is sized to relieve the total BTU input of the heating elements.

UL Listing

Cemline Electric Boilers meet testing and inspection requirements of Underwriters' Laboratories and are listed and labeled as required by Underwriters' Laboratories.

Thermometer and Pressure Gauge

Cemline Electric Boilers are furnished with a thermometer to monitor vessel temperature and a dial pressure gauge to monitor pressure within the vessel. These gauges are mounted in an easily accessible position so that they may be read from the floor. Steam boilers are furnished with pressure gauge only.

Step Controller

Cemline Electric Boilers are furnished with a solid state step controller. The step controller is programmable to allow for multiple rotation options to promote even wear on the elements. The controller can operate the boiler based upon temperature or outdoor reset. The controller can be configured to run a system pump and has an adjustable night setting to help reduce electrical consumption. Optionally, Cemline can provide remote set point via 4-20 from the building management system or can provide BACnet IP communication.

Steam Boilers

Cemline Electric Steam Boilers operating up to 15# steam are built to Section IV of the A.S.M.E. Code and bear the "H" stamp. Cemline Electric Steam Boilers above 15# steam are built to Section I of the A.S.M.E. Code and bear the "S" stamp. Steam boilers are furnished with gauge glass and water feeder or pump controller.



Hot Water Boilers

Vertical High Capacity - Small Footprint

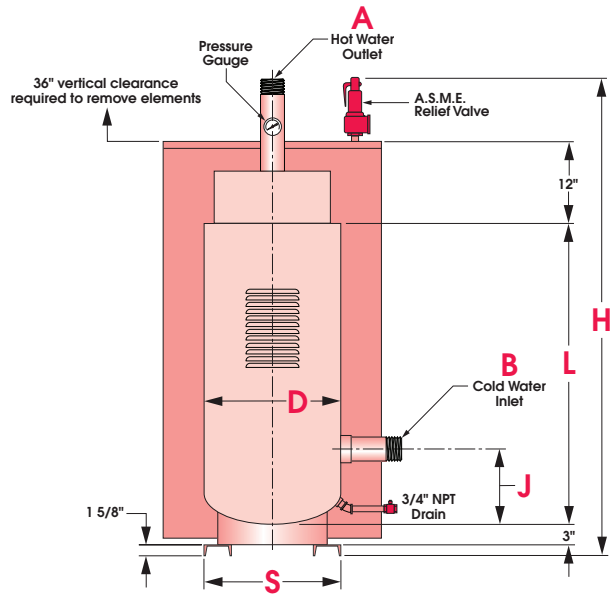

The dimensions suggested below are well proportioned and suitable for most installations. When building space or other conditions demand, other sizes are readily available. Please consult factory.

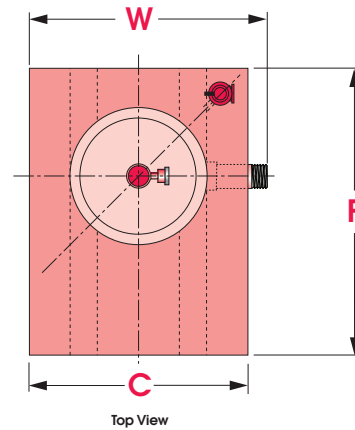

MODEL NUMBER	H	W	C	D	L	F	J	S	A&B
VB30ETB	70"	23"	20"	12"	44"	30"	11"	10"	3" NPT
VB40ETB	70"	27"	24"	16"	44"	34"	11"	14"	3" NPT
VB60ETB	70"	31"	28"	20"	44"	38"	11"	18"	3" NPT
VB80ETB	70"	35"	32"	24"	44"	42"	11"	22"	3" NPT

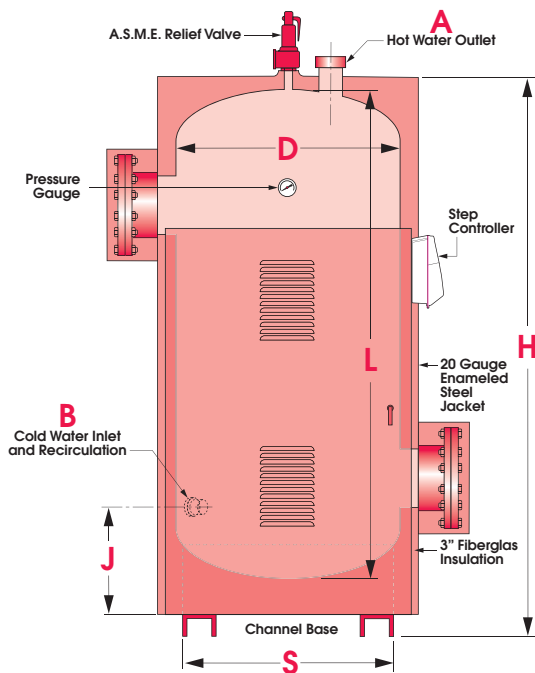

The dimensions suggested below are well proportioned and suitable for most installations. When building space or other conditions demand, other sizes are readily available. Please consult factory.

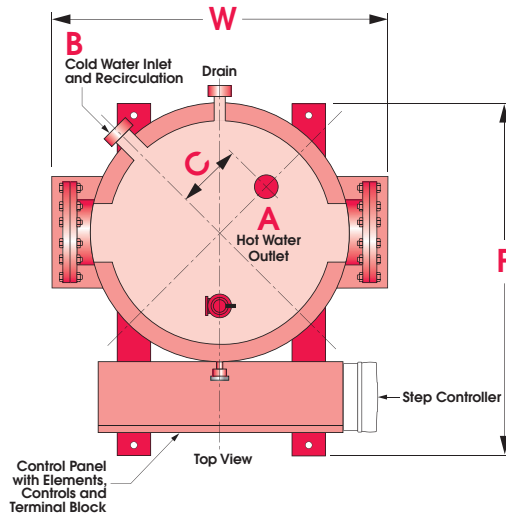

MODEL NUMBER	H	W	F	D	L	J	C	S	A&B
VB120FTB	70 1/2"	38"	36"	24"	63"	17 1/2"	6"	18"	4" NPT
VB200FTB	78 1/2"	42"	42"	30"	72"	19 1/2"	8"	24"	4" NPT
VB300FTB	79 1/2"	48"	50"	36"	72"	21 1/2"	8"	30"	6" NPT
VB370FTB	97 1/2"	56"	54"	36"	90"	25 1/2"	10"	36"	6" FLG.

Electric Boilers - Hot Water - 3 Phase Vertical High Capacity - Small Footprint

480V, 415V, 380V

Model No.	KW	Btu/Hr	Contactors	KW Per Circuit	Steps	KW Per Step	KW Per Element	Total # Elements	480V 3 Phase Amps	415V 3 Phase Amps	380V 3 Phase Amps
VB30ETB12	12	40,980	1	12	1	12	12	1	14	17	18
VB30ETB15	15	51,225	1	15	1	15	15	1	18	21	23
VB30ETB18	18	61,470	1	18	1	18	18	1	22	25	27
VB30ETB20	20	68,304	1	20	1	20	20	1	24	28	30
VB30ETB24	24	81,960	2	12	2	12	12	2	29	33	37
VB30ETB30	30	102,450	2	15	2	15	15	2	36	42	46
VB30ETB36	36	122,940	2	18	2	18	18	2	43	50	55
VB30ETB40	40	136,607	2	20	2	20	20	3	48	56	61
VB30ETB45	45	153,675	2	1@15, 1@30	2	1@15, 1@30	15	3	54	63	68
VB30ETB54	54	184,410	3	18	3	18	18	3	65	75	82
VB30ETB60	60	204,900	3	20	3	20	20	3	72	84	91
VB30ETB72	72	245,880	3	2@18, 1@36	3	2@18, 1@36	18	4	87	100	110
VB30ETB75	75	256,125	3	1@15, 2@30	3	1@15, 2@30	15	5	90	104	114
VB30ETB80	80	273,214	4	20	4	20	20	4	96	111	123
VB30ETB90	90	307,350	5	18	5	18	18	5	108	125	137
VB30ETB100	100	341,518	5	20	5	40	20	5	120	139	152
VB30ETB108	108	368,820	3	18	3	36	18	6	130	150	164
VB30ETB120	120	409,800	3	40	3	40	20	6	145	167	183
VB40ETB144	144	491,760	4	36	4	36	18	8	173	201	219
VB40ETB150	150	512,250	5	30	5	30	15	10	181	209	228
VB40ETB180	180	614,700	5	1@20, 4@40	5	1@20, 4@40	20	10	217	251	274
VB60ETB210	210	717,150	7	30	7	30	15	14	253	292	319
VB60ETB240	240	819,600	6	40	6	40	20	12	289	334	365
VB60ETB270	270	922,098	8	1@18, 7@36	8	1@18, 7@36	18	15	325	376	411
VB60ETB300	300	1,024,500	8	1@20, 7@40	8	1@20, 7@40	20	15	361	418	456
VB60ETB320	320	1,092,857	8	40	8	40	20	16	385	446	487
VB60ETB360	360	1,229,400	9	40	9	40	20	18	434	501	548
VB60ETB400	400	1,366,072	10	40	10	40	20	20	482	557	609
VB60ETB440	440	1,502,679	11	40	11	40	20	22	530	613	669
VB80ETB480	480	1,639,200	12	4@40, 4@80	8	4@40, 4@80	20	24	578	669	730
VB80ETB520	520	1,775,893	13	40	7	1@40, 6@80	20	26	626	724	791
VB80ETB560	560	1,912,500	14	40	7	80	20	27	674	780	852
VB80ETB600	600	2,049,000	15	1@40, 7@80	8	1@40, 7@80	20	30	723	836	913
VB120FTB660	660	2,253,900	22	30	11	60	10	66	795	919	1004
VB200FTB720	720	2,458,800	24	30	12	60	10	72	861	1003	1095
VB200FTB810	810	2,766,150	27	30	13	13@60, 1@30	10	81	975	1128	1232
VB200FTB900	900	3,073,500	30	30	15	60	10	90	1084	1254	1369
VB300FTB1080	1080	3,688,200	36	30	12	12@90	10	108	1301	1504	1643
VB300FTB1200	1200	4,098,215	40	30	14	12@90, 2@60	10	120	1445	1671	1825
VB300FTB1440	1440	4,917,858	40	36	14	12@108, 2@72	12	120	1734	2006	2190
VB300FTB1512	1512	5,163,751	42	36	14	14@108	12	126	1821	2106	2300
VB370FTB1584	1584	5,409,644	44	36	16	12@108, 4@72	12	132	1908	2206	2409
VB370FTB1656	1656	5,655,536	46	36	16	14@108, 2@72	12	138	1994	2307	2519
VB370FTB1728	1728	5,901,429	48	36	16	16@108	12	144	2081	2407	2629
VB370FTB1800	1800	6,147,000	50	36	18	14@108, 4@72	12	150	2168	2507	2738
VB370FTB2016	2016	6,885,001	56	36	20	16@108, 4@72	12	168	2428	2808	3067

240V, 208V

Model No.	KW	Btu/Hr	Contactors	KW Per Circuit	Steps	KW Per Step	KW Per Element	Total # Elements	Amp 240V	Amp 208V
VB30ETB12	12	40,980	1	12	1	12	12	1	29	33
VB30ETB15	15	51,225	1	15	1	15	15	1	36	42
VB30ETB24	24	81,960	2	12	2	12	12	2	58	67
VB30ETB30	30	102,450	2	15	2	15	15	2	72	83
VB30ETB45	45	153,675	3	15	3	15	15	3	108	125
VB30ETB60	60	204,900	4	15	4	15	15	4	145	167
VB30ETB75	75	256,125	5	15	5	15	15	5	181	208
VB30ETB90	90	307,366	6	15	6	15	15	6	217	250
VB30ETB105	105	358,594	7	15	7	15	15	7	253	292
VB30ETB120	120	409,800	8	15	8	15	15	8	289	333
VB40ETB150	150	512,250	10	15	5	30	15	10	361	417
VB40ETB180	180	614,700	12	15	6	30	15	12	434	500
VB60ETB210	210	717,150	14	15	7	30	15	14	506	583
VB60ETB240	240	819,600	16	15	8	30	15	16	578	666
VB60ETB270	270	922,098	18	15	9	30	15	18	650	750
VB60FTB300	300	1,024,500	20	15	10	30	15	20	723	833

Hot Water Boilers

Classic Vertical and Horizontal

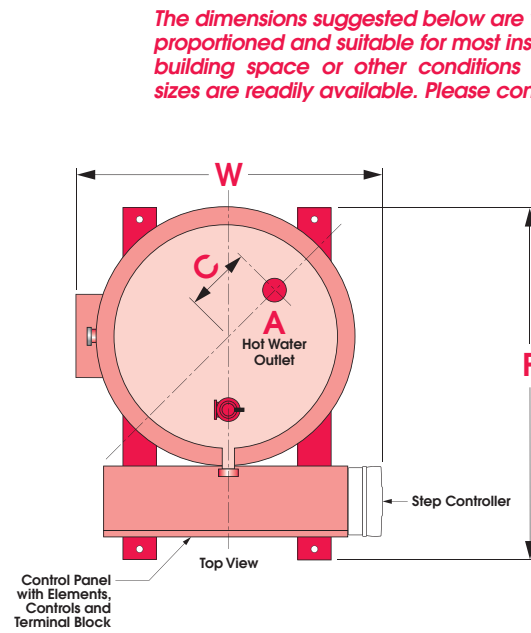
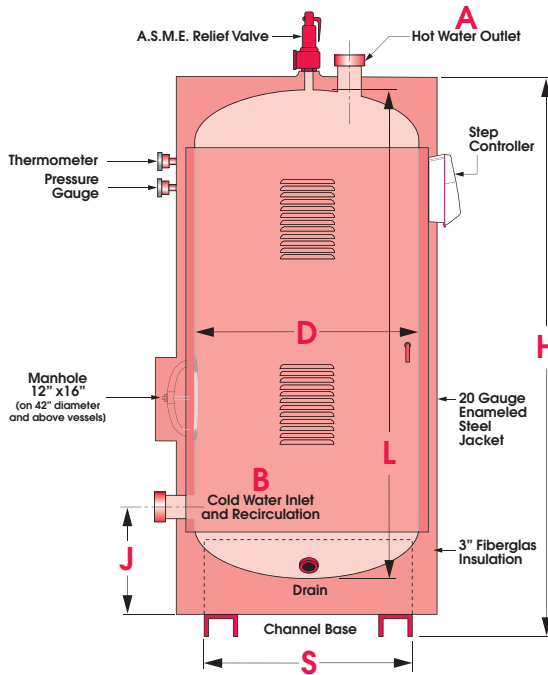

The dimensions suggested below are well proportioned and suitable for most installations. When building space or other conditions demand, other sizes are readily available. Please consult factory.

MODEL NUMBER	H	W	F	D	L	J	C	S	A & B
VB30EHB	37 1/2"	28"	28"	16"	30"	13 1/2"	4"	14"	1-1/2" NPT
VB40EHB	55 1/2"	28"	28"	16"	48"	13 1/2"	4"	14"	2-1/2" NPT
VB120EHB	70 1/2"	38"	36"	24"	63"	17 1/2"	6"	18"	3" NPT
VB200EHB	78 1/2"	42"	42"	30"	72"	19 1/2"	8"	24"	4" FLG.
VB300FTB	79 1/2"	48"	50"	36"	72"	21 1/2"	8"	30"	5" FLG.
VB450FTB	97 1/2"	56"	54"	42"	90"	25 1/2"	10"	36"	6" FLG.
VB600FTB	91 1/2"	60"	60"	48"	84"	26 1/2"	10"	42"	6" FLG.
VB750FTB	91 1/2"	66"	66"	54"	84"	27 1/2"	10"	48"	6" FLG.
VB950FTB	91 1/2"	72"	72"	60"	84"	29 1/2"	10"	54"	8" FLG.

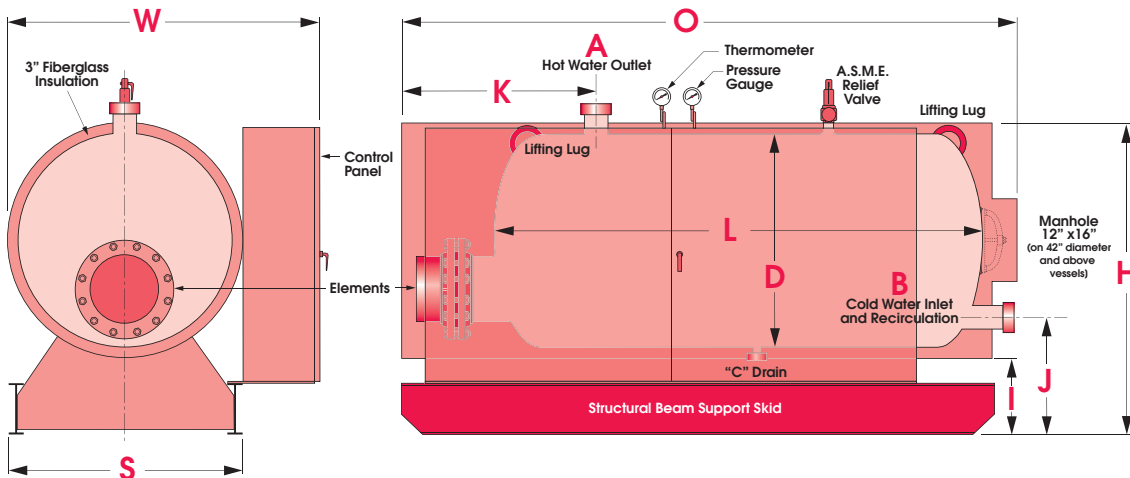

MODEL NUMBER	H	W	O	D	L	K	S	I	J	C	A&B
HB30EHB	30"	36"	51"	16"	30"	21"	20"	10"	16"	1"	1 1/2" NPT
HB40EHB	30"	36"	60"	16"	48"	21"	20"	10"	16"	1"	2 1/2" NPT
HB120EHB	38"	43"	93"	24"	60"	44"	28"	10"	16"	1"	3" NPT
HB200EHB	44"	49"	93"	30"	72"	44"	34"	10"	18"	1"	4" FLG.
HB300EHB	50"	55"	93"	36"	72"	44"	40"	10"	19"	1 1/2"	5" FLG.
HB450FTB	56"	61"	108"	42"	90"	44"	46"	10"	19"	1 1/2"	6" FLG.
HB600FTB	62"	67"	102"	48"	84"	44"	52"	10"	19"	1 1/2"	6" FLG.
HB750FTB	68"	73"	102"	54"	84"	44"	58"	10"	19"	1 1/2"	6" FLG.
HB950FTB	74"	79"	102"	60"	84"	44"	64"	10"	24"	1 1/2"	8" FLG.

Electric Boilers - Hot Water - 3 Phase Classic

480V, 415V,
380V

Model No.	KW	Btu/Hr	Circuits	KW Per Circuit	Steps	KW Per Step	KW Per Element	Total # Elements	480V 3 Phase Amps	415V 3 Phase Amps	380V 3 Phase Amps
B30EHB12	12	40,980	1	12	1	12	4	3	14	17	18
B30EHB15	15	51,225	1	15	1	15	5	3	18	21	23
B30EHB18	18	61,470	1	18	1	18	6	3	22	25	27
B30EHB24	24	81,960	2	12	2	12	4	6	29	33	37
B30EHB27	27	92,205	2	13.5	2	13.5	4.5	6	33	38	41
B30EHB30	30	102,450	2	15	2	15	5	6	36	42	46
B30EHB36	36	122,940	2	18	2	18	6	6	43	50	55
B30EHB40.5	40.5	138,308	3	13.5	3	13.5	4.5	9	49	56	62
B30EHB45	45	153,675	3	15	3	15	5	9	54	63	68
B30EHB54	54	184,410	3	18	3	18	6	9	65	75	82
B40EHB60	60	204,900	4	15	4	15	5	12	72	84	91
B40EHB72	72	245,880	4	18	4	18	6	12	87	100	110
B40EHB75	75	256,125	5	15	5	15	5	15	90	104	114
B40EHB81	81	276,615	5	3@15, 2@18	5	3@15, 2@18	5 & 6	15	98	113	123
B40EHB90	90	307,350	5	18	5	18	6	15	108	125	137
B40EHB96	96	327,840	6	4@18, 2@12	6	4@18, 2@12	6 & 4	18	116	134	146
B40EHB108	108	368,820	6	18	6	18	6	18	130	150	164
B120EHB120	120	409,800	7	6@18, 1@12	7	6@18, 1@12	10	12	145	167	183
B120EHB144	144	491,760	8	18	8	18	6	24	173	201	219
B120EHB150	150	512,250	5	30	5	30	10	15	181	209	228
B200EHB180	180	614,700	6	30	6	30	10	18	217	251	274
B200EHB210	210	717,150	7	30	7	30	10	21	253	292	319
B300EHB240	240	819,600	8	30	8	30	10	24	289	334	365
B300EHB300	300	1,024,500	10	30	10	30	10	30	361	418	456
B300FTB330	330	1,126,950	11	30	11	30	10	33	397	460	502
B300FTB360	360	1,229,400	12	30	12	30	10	36	434	501	548
B300FTB390	390	1,331,850	13	30	13	30	10	39	470	543	593
B300FTB420	420	1,434,300	14	30	14	30	10	42	506	585	639
B300FTB450	450	1,536,750	15	30	15	30	10	45	542	627	685
B450FTB480	480	1,639,200	16	30	16	30	10	48	578	669	730
B450FTB540	540	1,844,100	18	30	9	60	10	54	650	752	821
B450FTB600	600	2,049,000	20	30	10	60	10	60	723	836	913
B450FTB660	660	2,253,900	22	30	11	60	10	66	795	919	1004
B600FTB720	720	2,458,800	24	30	12	60	10	72	867	1003	1095
B600FTB810	810	2,766,150	27	30	14	13@60, 1@30	10	81	975	1128	1232
B600FTB900	900	3,073,500	30	30	15	60	10	90	1084	1254	1369
B750FTB1080	1080	3,688,200	36	30	18	60	10	108	1301	1504	1643
B750FTB1260	1260	4,302,900	42	30	21	60	10	126	1517	1755	1917
B750FTB1440	1440	4,917,600	48	30	24	60	10	144	1734	2006	2190
B750FTB1560	1560	5,327,400	52	30	24	20@60, 4@90	10	156	1879	2173	2373
B950FTB1680	1680	5,732,200	56	30	24	16@60, 8@90	10	168	2023	2340	2556
B950FTB1800	1800	6,147,000	60	30	24	12@60, 12@90	10	180	2168	2507	2738
B950FTB2040	2040	6,966,600	68	30	24	4@60, 20@90	10	204	2457	2841	3103

240V, 208V

Model No.	KW	Btu/Hr	Circuits	KW Per Circuits	Steps	KW Per Step	KW Per Element	Total # Elements	Amp 240V	Amp 208V
B30EHB12	12	40,980	1	12	1	12	4	3	29	33
B30EHB15	15	51,225	1	15	1	15	5	3	36	42
B30EHB18	18	61,470	1	18	1	18	6	3	43	50
B30EHB24	24	81,960	2	12	2	12	4	6	58	67
B30EHB27	27	92,205	2	13.5	2	13.5	4.5	6	65	75
B30EHB30	30	102,450	2	15	2	15	5	6	72	83
B30EHB36	36	122,940	2	18	2	18	6	6	87	100
B30EHB40.5	40.5	138,308	3	13.5	3	13.5	4.5	9	98	113
B30EHB45	45	153,675	3	15	3	15	5	9	108	125
B30EHB54	54	184,410	3	18	3	18	6	9	130	150
B40EHB60	60	204,900	4	15	4	15	5	12	145	167
B40EHB72	72	245,880	4	18	4	18	6	12	173	200
B40EHB75	75	256,125	5	15	5	15	5	15	181	208
B40EHB81	81	276,615	5	3@15, 2@18	5	3@15, 2@18	5 & 6	15	195	225
B40EHB90	90	307,350	5	18	5	18	6	15	217	250
B40EHB96	96	327,840	6	4@18, 2@12	6	4@18, 2@12	6 & 4	18	231	266
B40EHB108	108	368,820	6	18	6	18	6	18	260	300
B120EHB120	120	409,800	7	6@18, 1@12	7	6@18, 1@12	6 & 4	21	289	333
B120EHB144	144	491,760	8	18	8	18	6	24	347	400
B120EHB150	150	512,250	9	7@18, 2@12	9	7@18, 2@12	6 & 4	27	361	417
B120EHB180	180	614,700	10	18	10	18	6	30	434	500
B200FTB210	210	717,150	12	11@18, 1@12	12	11@18, 1@12	6 & 4	36	506	583
B300FTB240	240	819,600	16	12@18, 2@12	16	12@18, 2@12	6 & 4	48	578	666
B450FTB300	300	1,024,500	18	14@18, 4@12	9	7@36, 2@24	6 & 4	54	723	833

Steam Boilers Vertical and Horizontal

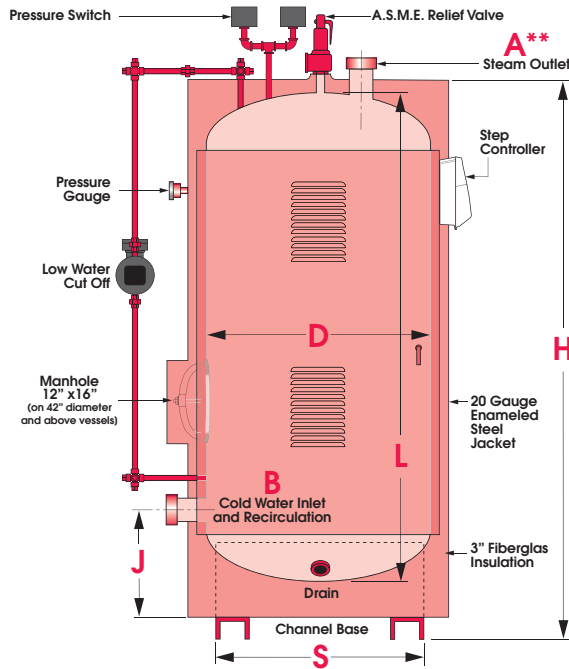

The dimensions suggested below are well proportioned and suitable for most installations. When building space or other conditions demand, other sizes are readily available. Please consult factory.

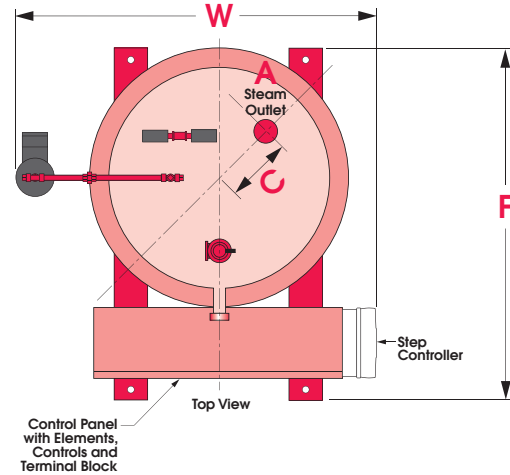

MODEL NUMBER	H	W	F	D	L	J	C	S	B
VB30EHB	37 1/2"	28"	28"	16"	30"	13 1/2"	4"	14"	1/2" NPT
VB40EHB	55 1/2"	28"	28"	16"	48"	13 1/2"	4"	14"	1/2" NPT
VB120EHB	70 1/2"	38"	36"	24"	63"	17 1/2"	6"	18"	1/2" NPT
VB200EHB	78 1/2"	42"	42"	30"	72"	19 1/2"	8"	24"	1/2" NPT
VB300FTB	79 1/2"	48"	50"	36"	72"	21 1/2"	8"	30"	1/2" NPT
VB450FTB	97 1/2"	56"	54"	42"	90"	25 1/2"	10"	36"	3/4" NPT
VB600FTB	91 1/2"	60"	60"	48"	84"	26 1/2"	10"	42"	3/4" NPT
VB750FTB	91 1/2"	66"	66"	54"	84"	27 1/2"	10"	48"	1" NPT
VB950FTB	91 1/2"	72"	72"	60"	84"	29 1/2"	10"	54"	1" NPT

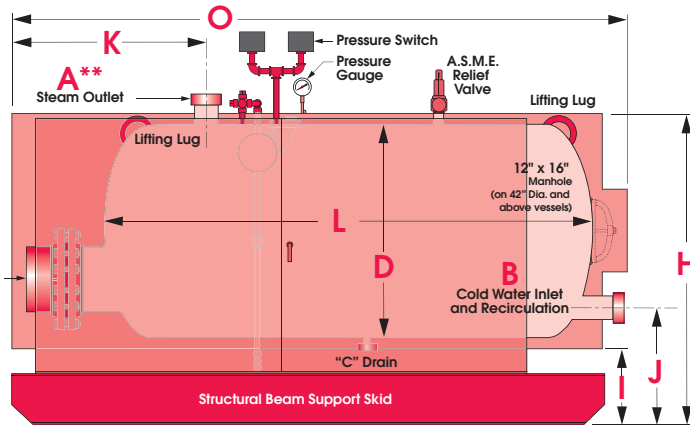
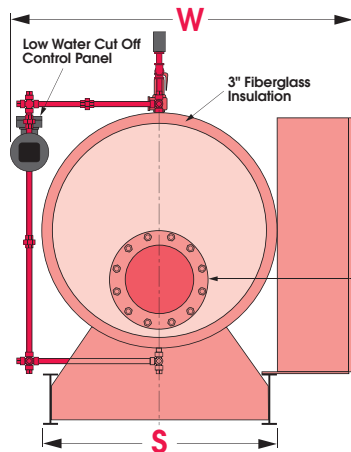

MODEL NUMBER	H	W	O	D	L	K	S	I	J	C	B
HB30EHB	30"	36"	51"	16"	30"	21"	20"	10"	16"	1"	1/2" NPT
HB40EHB	30"	36"	60"	16"	48"	21"	20"	10"	16"	1"	1/2" NPT
HB120EHB	38"	51"	93"	24"	60"	44"	28"	10"	16"	1"	1/2" NPT
HB200EHB	44"	57"	93"	30"	72"	44"	34"	10"	18"	1"	1/2" NPT
HB300EHB	50"	63"	93"	36"	72"	44"	40"	10"	19"	1 1/2"	1/2" NPT
HB450FTB	56"	69"	108"	42"	90"	44"	46"	10"	19"	1 1/2"	3/4" NPT
HB600FTB	62"	75"	102"	48"	84"	44"	52"	10"	19"	1 1/2"	3/4" NPT
HB750FTB	68"	81"	102"	54"	84"	44"	58"	10"	19"	1 1/2"	1" NPT
HB950FTB	74"	87"	102"	60"	84"	44"	64"	10"	24"	1 1/2"	1" NPT

** Dimension A is sized to suit generated steam capacity.

Electric Boilers - Steam - 3 Phase

480V, 415V,
380V

Model No.	KW	Btu/Hr	Steam #/Hr	Circuits	KW Per Circuit	Steps	KW Per Step	KW Per Element	Total # Elements	480V 3 Phase Amps	415V 3 Phase Amps	380V 3 Phase Amps
B30EHB12	12	40,980	42	1	12	1	12	4	3	14	17	18
B30EHB15	15	51,225	52	1	15	1	15	5	3	18	21	23
B30EHB18	18	61,470	63	1	18	1	18	6	3	22	25	27
B30EHB24	24	81,960	84	2	12	2	12	4	6	29	33	37
B30EHB27	27	92,205	94	2	13.5	2	13.5	4.5	6	33	38	41
B30EHB30	30	102,450	105	2	15	2	15	5	6	36	42	46
B30EHB36	36	122,940	126	2	18	2	18	6	6	43	50	55
B30EHB40.5	40.5	138,308	142	3	13.5	3	13.5	4.5	9	49	56	62
B30EHB45	45	153,675	157	3	15	3	15	5	9	54	63	68
B30EHB54	54	184,410	189	3	18	3	18	6	9	65	75	82
B40EHB60	60	204,900	210	4	15	4	15	5	12	72	84	91
B40EHB72	72	245,880	252	4	18	4	18	6	12	87	100	110
B40EHB75	75	256,125	262	5	15	5	15	5	15	90	104	114
B40EHB81	81	276,615	283	5	3@15, 2@18	5	3@15, 2@18	5 & 6	15	98	113	123
B40EHB90	90	307,350	315	5	18	5	18	6	15	108	125	137
B40EHB96	96	327,840	336	6	4@18, 2@12	6	4@18, 2@12	6 & 4	18	116	134	146
B40EHB108	108	368,820	378	6	18	6	18	6	18	130	150	164
B120EHB120	120	409,800	420	7	6@18, 1@12	7	6@18, 1@12	10	12	145	167	183
B120EHB144	144	491,760	504	8	18	8	18	6	24	173	201	219
B120EHB150	150	512,250	525	5	30	5	30	10	15	181	209	228
B200EHB180	180	614,700	630	6	30	6	30	10	18	217	251	274
B200EHB210	210	717,150	735	7	30	7	30	10	21	253	292	319
B300EHB240	240	819,600	840	8	30	8	30	10	24	289	334	365
B300EHB300	300	1,024,500	1050	10	30	10	30	10	30	361	418	456
B300FTB330	330	1,126,950	1162	11	30	11	30	10	33	397	460	502
B300FTB360	360	1,229,400	1260	12	30	12	30	10	36	434	501	548
B300FTB390	390	1,331,850	1373	13	30	13	30	10	39	470	543	593
B300FTB420	420	1,434,300	1470	14	30	14	30	10	42	506	585	639
B300FTB450	450	1,536,750	1584	15	30	15	30	10	45	542	627	685
B450FTB480	480	1,639,200	1680	16	30	16	30	10	48	578	669	730
B450FTB540	540	1,844,100	1890	18	30	9	60	10	54	650	752	821
B450FTB600	600	2,049,000	2100	20	30	10	60	10	60	723	836	913
B450FTB660	660	2,253,900	2310	22	30	11	60	10	66	795	919	1004
B600FTB720	720	2,458,800	2520	24	30	12	60	10	72	867	1003	1095
B600FTB810	810	2,766,150	2850	27	30	14	13@60, 1@30	10	81	975	1128	1232
B600FTB900	900	3,073,500	3150	30	30	15	60	10	90	1084	1254	1369
B750FTB1080	1080	3,688,200	3780	36	30	18	60	10	108	1301	1504	1643
B750FTB1260	1260	4,302,900	4400	42	30	21	60	10	126	1517	1755	1917
B750FTB1440	1440	4,917,600	5070	48	30	24	60	10	144	1734	2006	2190
B750FTB1560	1560	5,327,400	5400	52	30	24	20@60, 4@90	10	156	1879	2173	2373
B950FTB1680	1680	5,732,200	5900	56	30	24	16@60, 8@90	10	168	2023	2340	2556
B950FTB1800	1800	6,147,000	6300	60	30	24	12@60, 12@90	10	180	2168	2507	2738
B950FTB2040	2040	6,966,600	7180	68	30	24	4@60, 20@90	10	204	2457	2841	3103

240V, 208V

Model No.	KW	Btu/Hr	Steam #/Hr	Circuits	KW Per Circuits	Steps	KW Per Step	KW Per Element	Total # Elements	Amp 240V	Amp 208V
B30EHB12	12	40,980	42	1	12	1	12	4	3	29	33
B30EHB15	15	51,225	52	1	15	1	15	5	3	36	42
B30EHB18	18	61,470	63	1	18	1	18	6	3	43	50
B30EHB24	24	81,960	84	2	12	2	12	4	6	58	67
B30EHB27	27	92,205	94	2	13.5	2	13.5	4.5	6	65	75
B30EHB30	30	102,450	105	2	15	2	15	5	6	72	83
B30EHB36	36	122,940	126	2	18	2	18	6	6	87	100
B30EHB40.5	40.5	138,308	142	3	13.5	3	13.5	4.5	9	98	113
B30EHB45	45	153,675	157	3	15	3	15	5	9	108	125
B30EHB54	54	184,410	189	3	18	3	18	6	9	130	150
B40EHB60	60	204,900	210	4	15	4	15	5	12	145	167
B40EHB72	72	245,880	252	4	18	4	18	6	12	173	200
B40EHB75	75	256,125	262	5	15	5	15	5	15	181	208
B40EHB81	81	276,615	283	5	3@15, 2@18	5	3@15, 2@18	5 & 6	15	195	225
B40EHB90	90	307,350	315	5	18	5	18	6	15	217	250
B40EHB96	96	327,840	336	6	4@18, 2@12	6	4@18, 2@12	6 & 4	18	231	266
B40EHB108	108	368,820	378	6	18	6	18	6	18	260	300
B120EHB120	120	409,800	420	7	6@18, 1@12	7	6@18, 1@12	6 & 4	21	289	333
B120EHB144	144	491,760	504	8	18	8	18	6	24	347	400
B120EHB150	150	512,250	525	9	7@18, 2@12	9	7@18, 2@12	6 & 4	27	361	417
B120EHB180	180	614,700	630	10	18	10	18	6	30	434	500
B200FTB210	210	717,150	735	12	11@18, 1@12	12	11@18, 1@12	6 & 4	36	506	583
B300FTB240	240	819,600	840	16	12@18, 2@12	16	12@18, 2@12	6 & 4	48	578	666
B450FTB300	300	1,024,500	1050	18	14@18, 4@12	9	7@36, 2@24	6 & 4	54	723	833

Sample Specification Electric Boilers

Steam Calculations:

Gauge Pounds	Boiling Point of Water
0	212° F.
1	215° F.
3	219° F.
5	227° F.
8	235° F.
10	239° F.
12	244° F.
15	250° F.

Boiling point of water at various pressures

Note: For steam boilers the pounds per hour column is at 212°F. The designer must add for heating the water from starting to ending temperature.

Example:

To produce 210# per hour of steam at 15 psi with feedwater at 80° F. To heat water from 80° to 250° (15 psi steam temperature)

$$250 - 80 = 170^\circ$$

170° x 210# per hour = 35,700 BTU per hour
steam (from chart) 204,900 BTU per hour

Total 240,600 BTU per hour

Choose 72 KW — 245,880 BTU per hour

Specifying Boiler Model Number

- Select desired voltage.
 - 208, 240, 380, 415, 480 volt
- Select KW, BTU/hour, or lbs. steam/hour.
- Select horizontal or vertical configuration.
- Select any optional extras as listed on page 2.

Specifying a Cemline Boiler Model Number:

*Example:

Interpretation:

- "V" for vertical configuration.
"H" for horizontal configuration.
- Cemline Boiler Number.
- Symbol designating voltage — select from code below:

Voltage	Phase	Code
208	1	BY1
208	3	BY3
240	1	B1
240	3	B3
480	1	C1
480	3	C3
415	1	CY1
415	3	CY3
380	1	BZ1
380	3	BZ3
400	1	BX1
400	3	BX3

- Symbol for U.L. listing.

*Example shown above is for a vertical boiler, 75 KW, 480 volt, 3 phase.

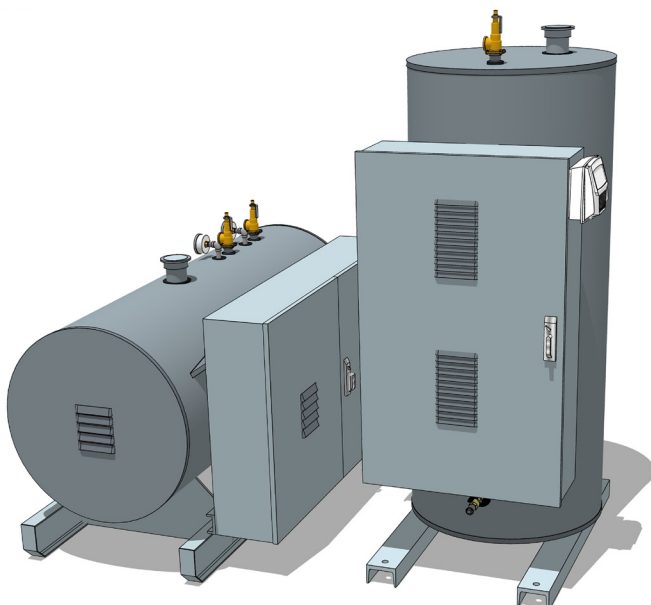



STONESTEEL is a Registered Trademark of Cemline Corporation



Specifying Electric Boilers

Electric Package Hot Water Boiler shall be as manufactured by Cemline Corporation. Boiler shall be constructed and stamped in accordance with the latest A.S.M.E. Code, and shall be registered with the National Board of Boiler and Pressure Vessel Inspectors. The boiler shall also meet the requirements of Underwriters' Laboratories and be so labeled.

The boiler shall be furnished with 3" fiberglass insulation and 20 gauge enameled steel jacket. Elements shall be incoloy sheathed resistance type, individually removable and replaceable.

Magnetic contactors shall be factory installed, and shall disconnect all ungrounded conductors to each heater circuit. Control circuit voltage shall be 120 volts. Factory furnished built-in class "J" fuses shall be provided in each ungrounded conductor of each contactor circuit.

An "on-off" control switch shall be furnished. Red indicating lights shall be provided to indicate the boiler is operating, a high temperature condition or low water condition.

A solid state modulating progressive sequencing step control with the proper number of steps shall control the heater contactors and be capable of turning off the step that has been on longest and turning on the step that has been off the longest. Step controller shall have recycle relay and built-in pilot lights. Each step and function of the solid state step controller must be modular with individual plug in modules. A manual reset high limit thermostat (pressure switch with steam) shall be furnished to de-energize all contactors upon actuation. thermometer, pressure gauge and A.S.M.E. rated safety relief valve shall be provided.

Boiler shall be factory prewired to terminal strip ready for connection to external power supply wiring. All contactors and controls (except those required to be mounted on the vessel) shall be housed in a NEMA I Enclosure with key lock door. Boiler shall have one year warranty against defects in materials and workmanship.

Boiler shall be Cemline Model _____. Boiler shall have _____ KW input and shall operate on _____ volt, _____ phase _____ cycle current. Boiler shall be designed for _____ psi working pressure.



www.cemline.com

- Product Sizing Programs
- Brochures
- I.O.M. Manuals
- Drawings & Specifications
- Agent Locator
- Plant Tour

©2021 Cemline Corporation All Rights Reserved.

All trademarks on this brochure are the property of Cemline Corporation, unless otherwise noted or in any other way set forth as a third party rights. Unauthorized use of these trademarks, as well as the materials presented on this site, is expressly prohibited and constitutes a violation of the intellectual property rights of Cemline Corporation.

Vol. 3.5



Scan to view our mobile web link.

CEMLINE CORPORATION

P.O. BOX 55 CHESWICK, PENNSYLVANIA 15024
Phone: (724) 274-5430 FAX: (724) 274-5448

www.cemline.com